

SINCE 1839

BRINLY

Customer Service
Toll Free
877-728-8224

OWNER'S MANUAL

SERIES BS-38

MODEL NO.

BS-381

38" BOX SCRAPER

- Assembly
- Installation
- Operation
- Repair Parts

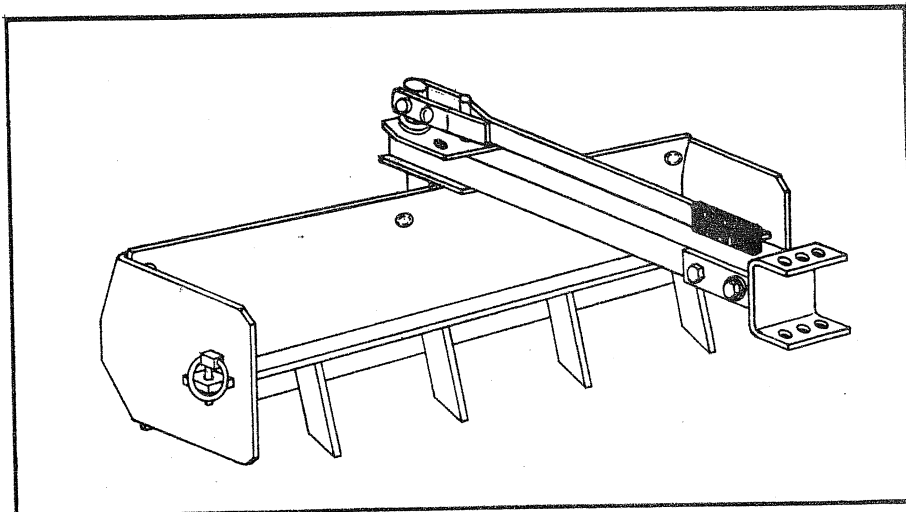

THIS IMPLEMENT FOR USE WITH GARDEN TRACTORS EQUIPPED WITH SLEEVE HITCH.
ALSO, TIRE CHAINS AND WHEEL WEIGHTS ARE RECOMMENDED.

"IMPORTANT: THIS MANUAL CONTAINS INFORMATION FOR THE SAFETY OF PERSONS AND PROPERTY. READ IT CAREFULLY BEFORE ASSEMBLY AND OPERATION OF THE EQUIPMENT!"

LIMITED WARRANTY

Brinly-Hardy Company warrants only to the original retail purchaser that this product will remain free of defects in workmanship and materials under normal use and service for a period of one (1) year (NOTE: ninety (90) days for commercial or rental use) commencing with the date of purchase.

Any parts found to be defective within the warranty period will be replaced, with proof of date of purchase, at Brinly Hardy Company's expense. Our obligation under this warranty is expressly limited to replacement or repair, at our option of parts which are defective in material or workmanship within thirty (30) days of receipt of the parts. This warranty does not apply to damage caused by unreasonable use, including failure to provide necessary maintenance, nor does it apply to any transportation or labor charges.

WE MAKE NO OTHER EXPRESS WARRANTY NOR IS ANYONE AUTHORIZED TO MAKE ANY ON OUR BEHALF. ANY IMPLIED OR STATUTORY WARRANTIES, INCLUDING ANY WARRANTY OF MERCHANTABILITY OR FITNESS FOR A PARTICULAR PURPOSE, ARE LIMITED TO THE DURATION OF THIS WRITTEN WARRANTY. WE SHALL NOT BE LIABLE FOR CONSEQUENTIAL OR INCIDENTAL DAMAGES OF ANY KIND.

BRINLY-HARDY COMPANY 1-800-626-5329

MADE IN U.S.A.

CONGRATULATIONS on your purchase of this Brinly Implement. It has been designed, engineered, and manufactured to give you the best possible dependability and performance.



Please read and retain this manual. The instructions will enable you to assemble and maintain your Implement properly. Always observe the "SAFETY RULES".

Should the need ever exist for repair parts, order through most any Lawn and Garden dealer, using part number and description.



RULES FOR SAFE OPERATION

- Know controls and how to stop quickly, READ THE OWNER'S MANUAL.
- Do not allow children to operate the vehicle, do not allow adults to operate without proper instruction or without having read the owner's manual.
- Do not carry passengers. Keep children and pets, a safe distance away.
- Always wear substantial footwear. Do not wear loose fitting clothing that can get caught in moving parts.
- Keep your eyes and mind on your tractor/attachment and area being covered. Do not let other interests distract you.
- Stay alert for holes in the terrain and other hidden hazards.
- Do not drive close to creeks, ditches and public highways.
- Watch out for traffic when crossing or near roadways.
- When using any attachment, don't allow anyone near the vehicle while in operation.
- Keep the vehicle and attachment in good operating condition and keep safety devices in place.
- Keep all nuts, bolts and screws tight to be sure the equipment is in safe working condition.
- The vehicle and attachment should be stopped and inspected for damage after striking a foreign object. The damage should be repaired before restarting and operating the equipment.
- See tractor equipment owner's manual for safe operation of the equipment.



WARNING!

- Always stop the tractor and raise Unit to transport position BEFORE changing blade angle or reversing blade.
- Care should be taken not to "hang" the blade on surface projections such as corners of concrete driveways.
- NEVER allow anyone to "ride" on the Unit.
- Lock Tractor Lift Handle DOWN when installing Unit on or removing from the Sleeve Hitch.



LOOK FOR THIS SYMBOL TO POINT OUT IMPORTANT SAFETY PRECAUTIONS. IT MEANS - ATTENTION! BECOME ALERT! YOUR SAFETY IS INVOLVED.

CUSTOMER RESPONSIBILITIES

- Read and observe the "SAFETY RULES".
- Follow a regular schedule in maintaining, caring for and using your Implement.

TABLE OF CONTENTS

| | |
|----------------------|---|
| WARRANTY..... | 1 |
| SAFETY RULES..... | 2 |
| CARTON CONTENTS..... | 3 |
| ASSEMBLY..... | 4 |

| | |
|------------------------------|---|
| ADJUSTMENTS..... | 5 |
| OPERATION..... | 5 |
| CUSTOMER RESPONSIBILITY..... | 5 |
| REPAIR PARTS..... | 6 |

CONTENTS OF SHIPPING CARTON

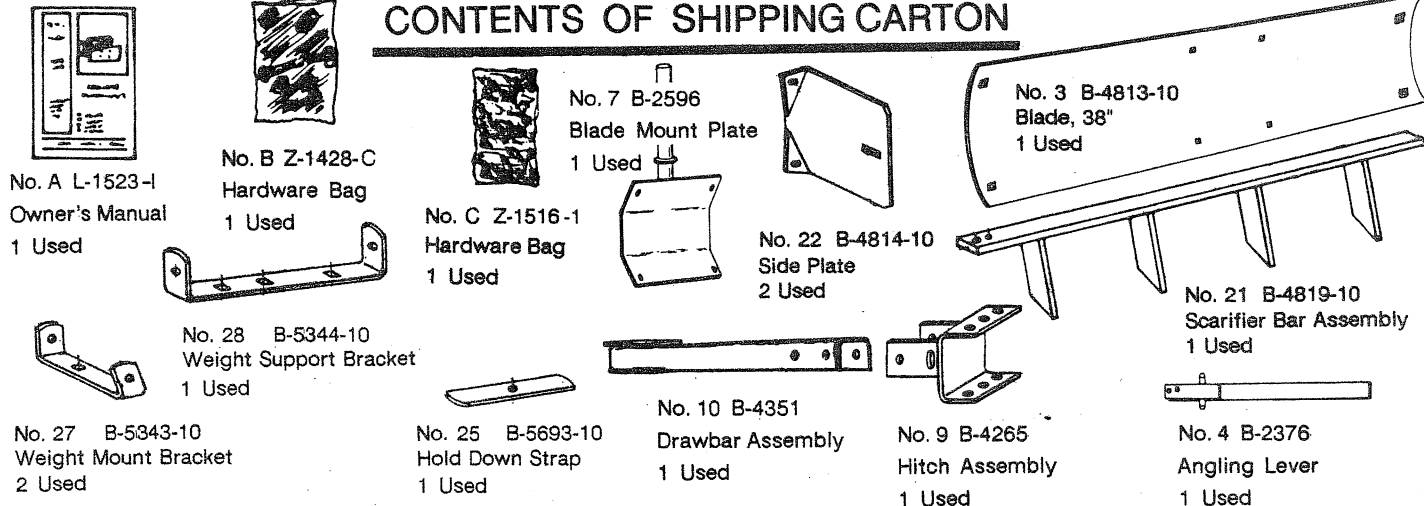

Z-1428-C HARDWARE BAG (ACTUAL SIZE)

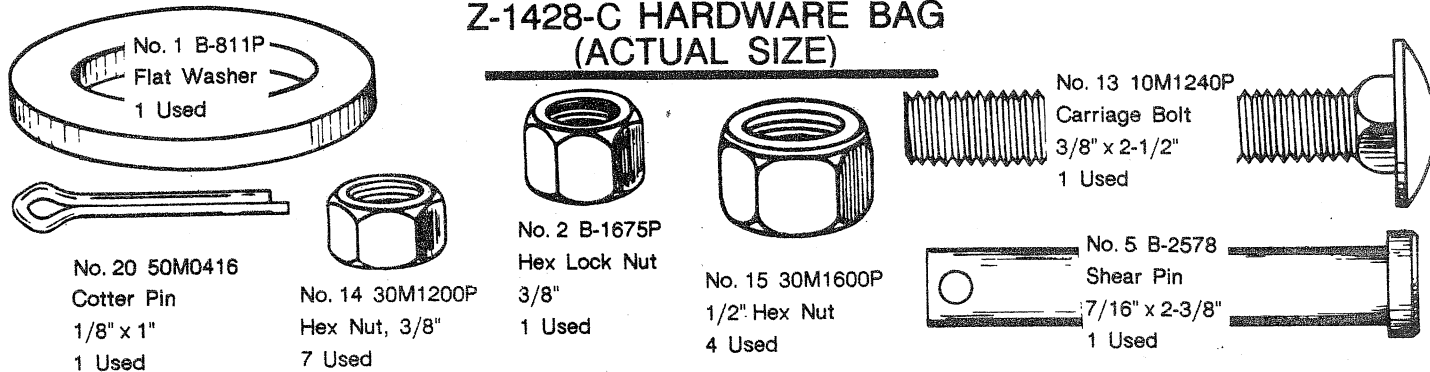

Z-1516-1 HARDWARE BAG (ACTUAL SIZE)

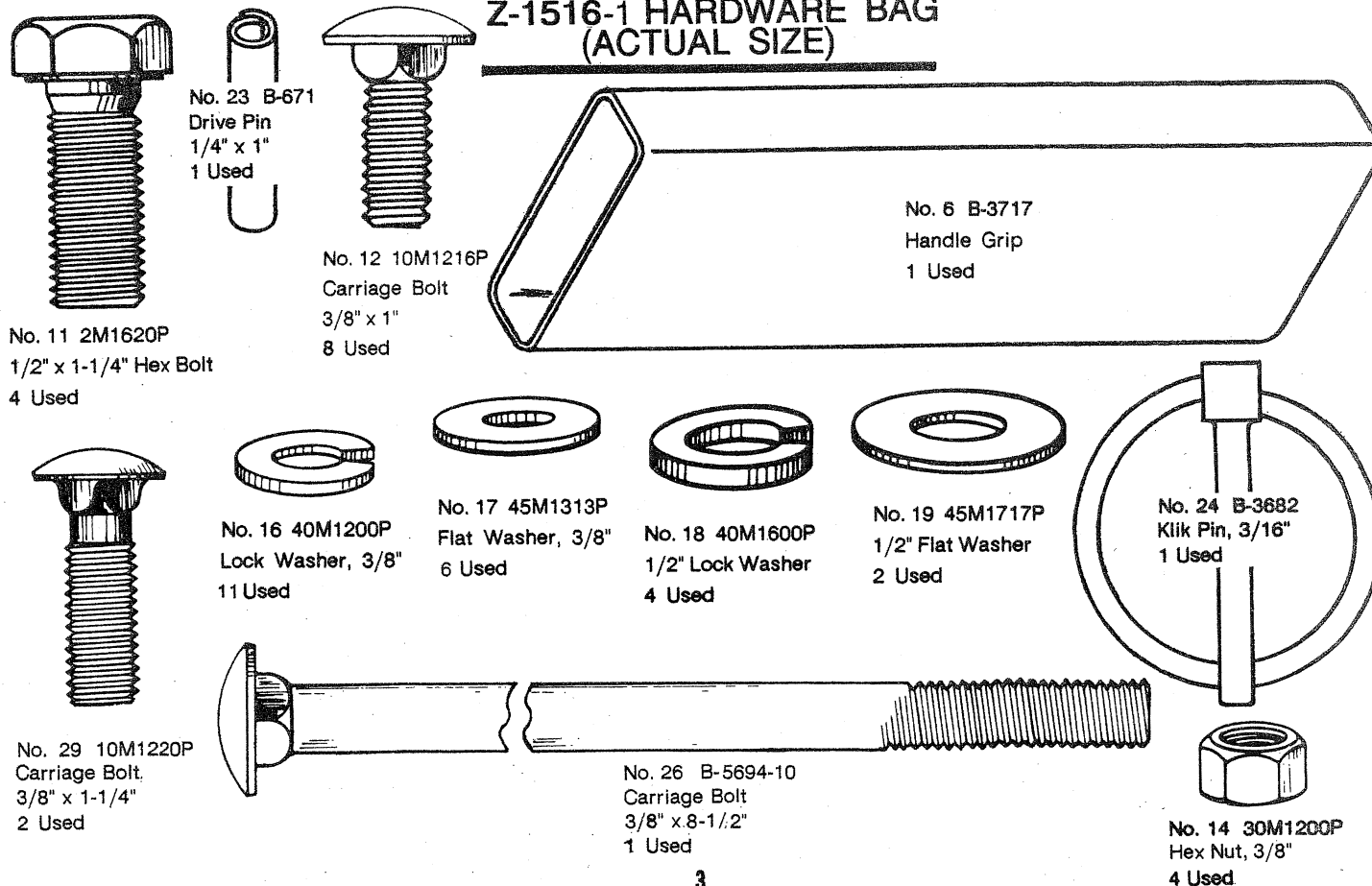

ASSEMBLY

NOTES:

- It is recommended that you carefully read this Owner's Manual before starting assembly.
- Right hand (R.H.) and Left hand (L.H.) are determined from the Operator's position while seated on the tractor.

Refer to FIG. 1

- Attach the Blade to the Blade Mount Plate in the two TOP HOLES of each, using two 3/8" x 1" Carriage Bolts, 3/8" Lock Washers, 3/8" Flat Washers (Next to Slots), and secure loosely with 3/8" Hex Nuts. Do not tighten these fasteners.
- Assemble Weight Mount Brackets (V-Angle End next to Blade Mount Plate) to two BOTTOM HOLES Blade and Blade Mount Plate using two 3/8" x 1-1/4" Carriage Bolts, 3/8" Lock Washers and secure loosely with 3/8" Hex Nuts. Do not tighten at this time.
- Attach the Weight Support Bracket to bottom of Weight Mount Brackets using the outside holes with 3/8" x 1" Carriage Bolts, 3/8" Lock Washers, securing with 3/8" Hex Nuts.
- Now securely tighten all hardware.

Refer to FIG. 2

- Attach the Hitch Assembly to the Drawbar using four 1/2" x 1-1/4" Hex Bolts, Lock Washers and nuts. Two 1/2" Flat Washers assemble next to slots in the Hitch Assembly. Do not tighten at this time.
- Slip the Drawbar down the Blade Mount Plate Post as shown in the Illustration.
- Slip the Large Flat Washer down the post followed by the Angling Lever as shown.
- Insert the 7/16" x 2-3/8" Shear Pin through the round holes in Lever and Post.
- Insert the 1/8" x 1" Cotter Pin through the hole in the end of Shear Pin and bend legs over.
- Insert 3/8" x 2-1/2" Carriage Bolt through the remaining two holes (square) in the Angling Lever and secure with the 3/8" Hex Lock Nut. Tighten the Lock Nut just enough to remove any "looseness" in the Angling Lever -- it must be free to move up and down without binding.
- Slide the Handle Grip onto the end of the Angling Lever.

Refer to Fig. 3

- Attach two Side Plates to ends of Blade using 3/8" x 1" Carriage Bolts, Flat Washers (Next to slots), Lock Washers and Hex Nuts as shown. Tighten securely!
 - Hammer Drive Pin into the second hole in the end of Scarifier Bar until an equal amount protrudes on each side of Bar.
 - Install Scarifier Bar Assembly (Teeth Points down and facing forward) into slots of Side Plates as shown. The end without Drive Pin must slide in first. Secure in place by installing the Klik Pin on the outside of Side Plate and in the end hole of Scarifier Bar as shown.
- NOTE: When Scarifier Bar Assembly is not used, it can be removed or re-installed with teeth protruding upward.

TOOLS REQUIRED FOR ASSEMBLY:

- 1 - 9/16" Wrench
- 2 - 3/4" Wrenches
- 1 - Pair of Pliers (Slip - joint recommended)
- 1 - Level
- 1 - Hammer

NOTE: A 3/8" x 8-1/2" Carriage Bolt, Hold Down Strap, 3/8" Lock Washer and 3/8" Hex Nut is provided when a Concrete Block is used for extra weight. (See Fig. 1).

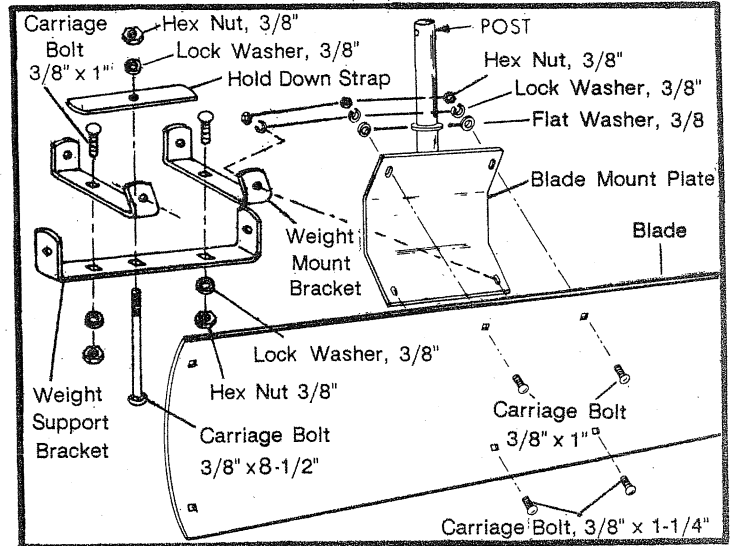

FIG. 1

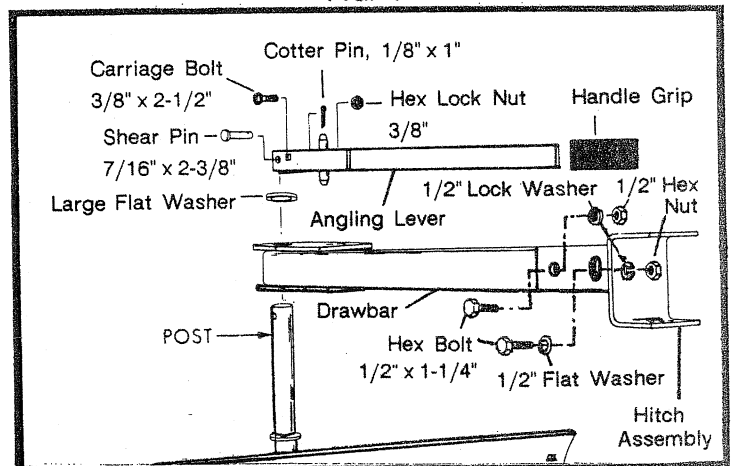

FIG. 2

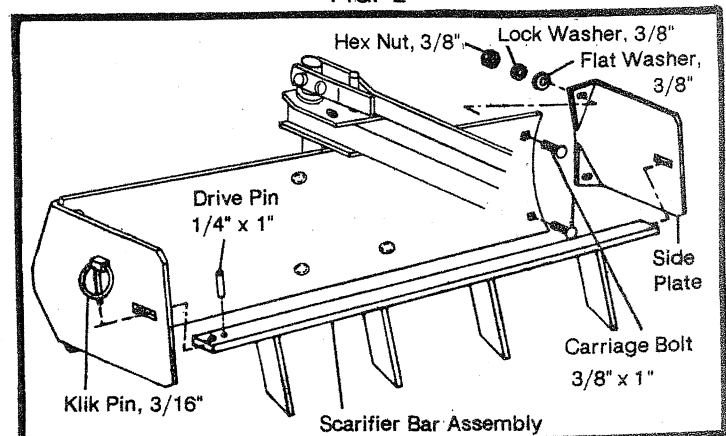

Fig. 3.

ADJUSTMENTS

Refer to Fig. 4

NOTE: Attach the completed Box Scraper to the Sleeve Hitch on your Tractor, in the middle hole of Box Scraper Hitch, using the Hitch Pin furnished with your Hitch. Now the Stabilizer Bolts on the Hitch need to be tightened against the Yoke on Box Scraper to prevent any "side sway".

- Position the Tractor(with Box Scraper) on a hard, level surface.
- Lower the Box Scraper and check to make sure it is level side-to-side, and then tighten the four 3/8" Carriage Bolts, holding the Box Scraper to the Post.
- Place a level on top of Drawbar-move Hitch Assembly until Drawbar is level, front to back. Tighten the four 1/2" Hex Bolts securely.
- The operating depth of the Box Scraper needs to be set now. Make sure the Tractor Hitch is free to allow Box Scraper to go below ground level, but still maintaining a 5" transport height with Hitch raised.

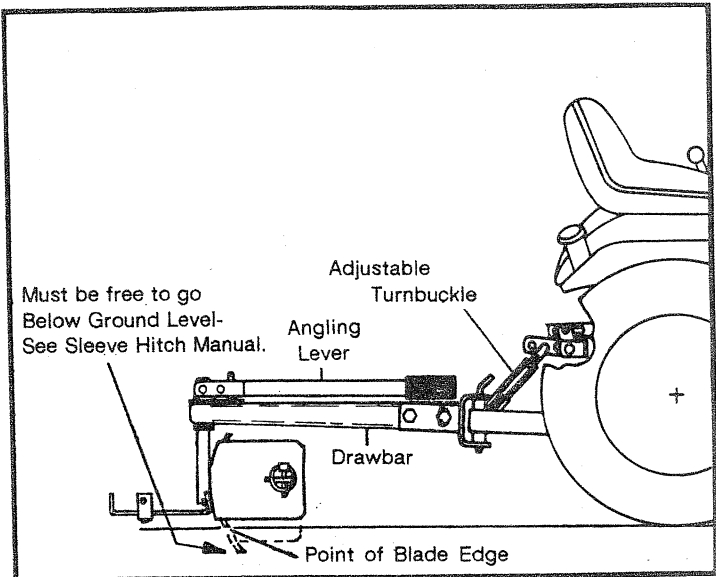

Fig. 4

Refer to your Tractor and/or Sleeve Hitch Manual for any necessary adjustments.

OPERATION

OPERATED AS A BOX SCRAPER AND SCARIFIER

- After the Box Scraper is properly adjusted and mounted to the Tractor, many different operations can be accomplished, some of which are: leveling dirt and gravel, spreading a pile of loose material, filling small holes, cleaning up debris, snow removal, scarifying, etc. NOTE: The Box Scraper is not recommended for use in reverse gear.
 - The Tractor speed while operating the unit, should be governed by the task to be accomplished.
 - While leveling or grading, do not attempt to cut excessive amounts of hard-packed material at a high rate of speed.
 - Use of the Scarifier is recommended when leveling and grading hard-packed material, to aid in breaking up the surface or gravel layer.
- NOTE: Operate at a speed which allows loose material that has piled up on the face of the Unit to be deposited in low areas.

OPERATED AS A REAR BLADE

- Your Unit may be used as a Rear Blade by removing the Scarifier and Side Plates (see instructions and illustration- Fig. 3).
- Various angles (left and right) are obtained by lifting Angling Lever, rotating the Blade to the desired angle, then lowering the Angling Lever into the locking hole.
- To use the Blade with the Tractor in the reverse gear, raise the Angling Lever, rotate the Blade 180 degrees and lock into the desired position.
- The Blade is designed to be used in a variety of light jobs: such as leveling, scraping, raking, back-filling, snow removal, etc.

NOTE: A 3/8" x 8-1/2" Carriage Bolt, Hold Down Strap, 3/8" Lock Washer and 3/8" Hex Nut is provided when a Concrete Block is used for extra weight. Refer to Fig. 1 and the Parts Page.

CUSTOMER RESPONSIBILITY

- After the Blade Edge has worn considerably, it should be rotated (from bottom to top) to provide a "new" edge. Remove the four 3/8" Carriage Bolts, rotate the Blade, and then re-assemble the Blade with "new" edge on the surface.
- Lubricate all pivoting points and the Hitch Pin with a drop or two of 30 weight oil before each operation.
- Frequently (at least every 8 hours of use) see that all bolts and nuts are tight.
- When the Unit is not being used, remove all dirt, scale and rust; then touch-up with paint.
- Apply a coat of grease, oil or rust preventive to blade edge, scarifier and other areas that appear to have "scoured" from operation.
- Always store in a dry place.

38" BOX SCRAPER

TO ORDER PARTS:

BRINLY HARDY COMPANY
P.O. BOX 18
JEFFERSONVILLE, IN.
47131-0018

1-800-626-5329

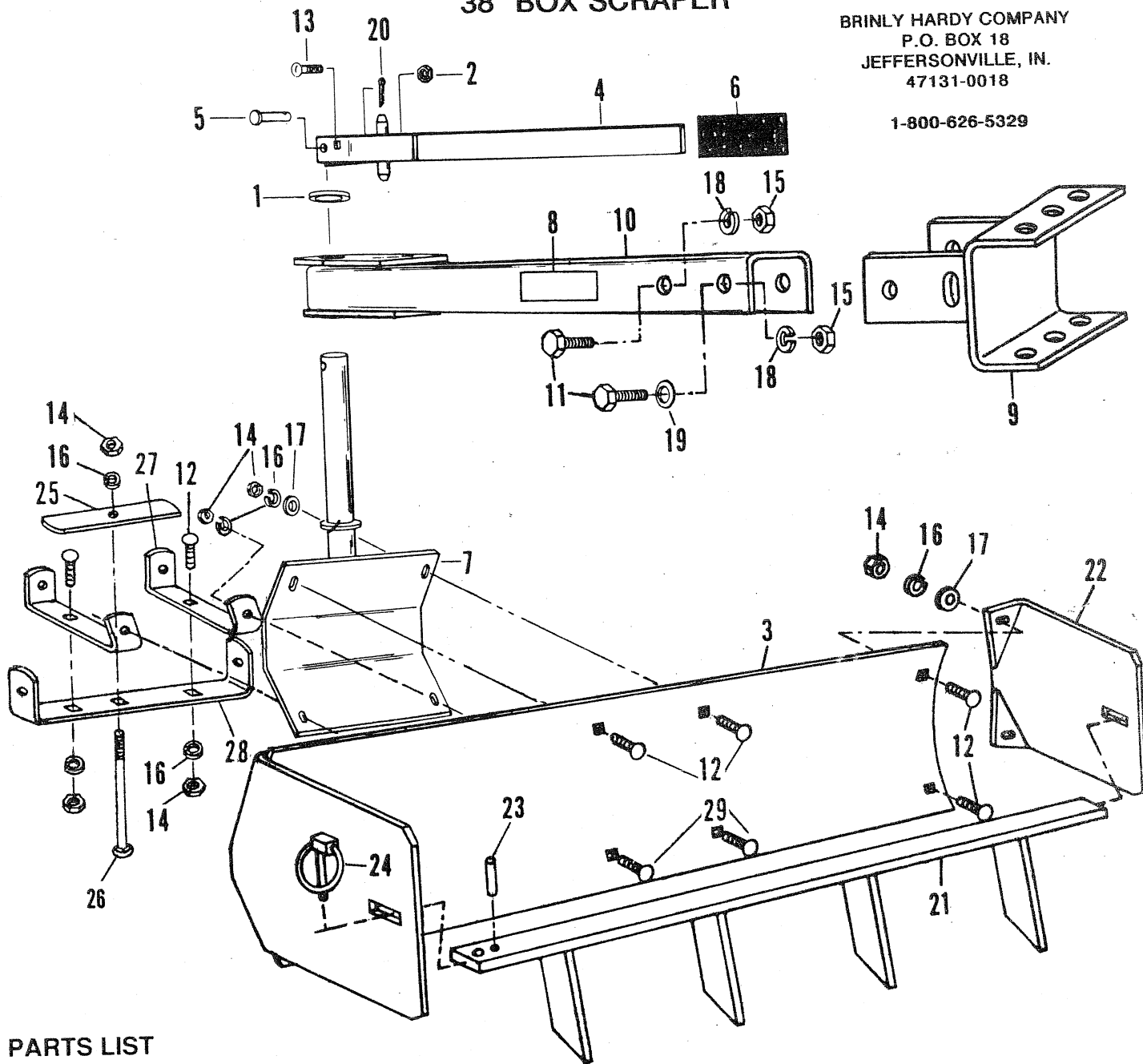

PARTS LIST

| Ref. No. | Part No. | Description | Qty. | Ref. No. | Part No. | Description | Qty. |
|----------|-----------|------------------------------|------|----------|-----------|------------------------------|------|
| 1 | B-811-P | Flat Washer (Bushing) | 1 | 16 | 40M1200P | Lock Washer, 3/8" | 11 |
| 2 | B-1675P | Hex Lock Nut, 3/8" | 1 | 17 | 45M1313P | Flat washer, 3/8" | 6 |
| 3 | B-4813-10 | Blade, 38" | 1 | 18 | 40M1600P | Lock Washer, 1/2" | 4 |
| 4 | B-2376-10 | Angling Lever | 1 | 19 | 45M1717P | Flat Washer, 1/2" | 2 |
| 5 | B-2578 | Shear Pin, 7/16" x 2-3/8" | 1 | 20 | 50M0416P | Cotter Pin, 1/8" x 1" | 1 |
| 6 | B-3717 | Handle Grip | 1 | 21 | B-4819-10 | Scarifier Bar Assembly | 1 |
| 7 | B-2596-10 | Blade Mount Plate | 1 | 22 | B-4814-10 | Side Plate | 2 |
| 8 | B-5922 | Logo Decal | 1 | 23 | B-671 | Drive Pin, 1/4" x 1" | 1 |
| 9 | B-4265-10 | Hitch Assembly | 1 | 24 | B-3682 | Klik Pin, 3/16" | 1 |
| 10 | B-4351-10 | Drawbar | 1 | 25 | B-5693-10 | Hold Down Strap | 1 |
| 11 | 2M1620P | Hex Bolt, 1/2" x 1-1/4" | 4 | 26 | B-5694 | Carriage Bolt, 3/8" x 8-1/2" | 1 |
| 12 | 10M1216P | Carriage Bolt, 3/8" x 1" | 8 | 27 | B-5343-10 | Weight Mount Bracket | 2 |
| 13 | 10M1240P | Carriage Bolt, 3/8" x 2-1/2" | 1 | 28 | B-5344-10 | Weight Support Bracket | 1 |
| 14 | 30M1200P | Hex Nut, 3/8" | 11 | 29 | 11M1220P | Carriage Bolt, 3/8" x 1-1/4" | 2 |
| 15 | 30M1600P | Hex Nut, 1/2" | 4 | | | | |