



INSTRUCTIONS FOR INSTALLING AND OPERATING
THE AM35852 REAR HYDRAULIC SYSTEM AND
BM15850 3-POINT HITCH



BM15850, AM35852, M80377

M80377 Instructions

NOTE: To install the AM35852 Rear Hydraulic System on a 140 Tractor, AM36001 Conversion Kit will be required.

CONTENTS

	Page
Installing Rear Hydraulic System on 300 Tractor	
System Controlled by Outer Hydraulic Control Lever	2
System Controlled by Inner Hydraulic Control Lever	4
Installing 3-Point Hitch on 300 or 140 Tractors	6
Mounting Ferrules	6
Attaching Hitch on Tractor	7
Cylinder Lock-Out Link.....	8
Lubrication	8
Operation and Adjustment of 3-Point Hitch	9
Removal of 3-Point Hitch	10

SPECIFICATIONS

Mast Height	12 inches (30.48 cm)	Lift Range.....	10 inches (25.40 cm)
Hitch Point Spread.	20 inches (50.80 cm)	Lift Capacity.....	400 lbs. (181.44 kg)*
Leveling Adjustment Range.....	4 inches (10.16 cm)	*With maximum front end ballast.	

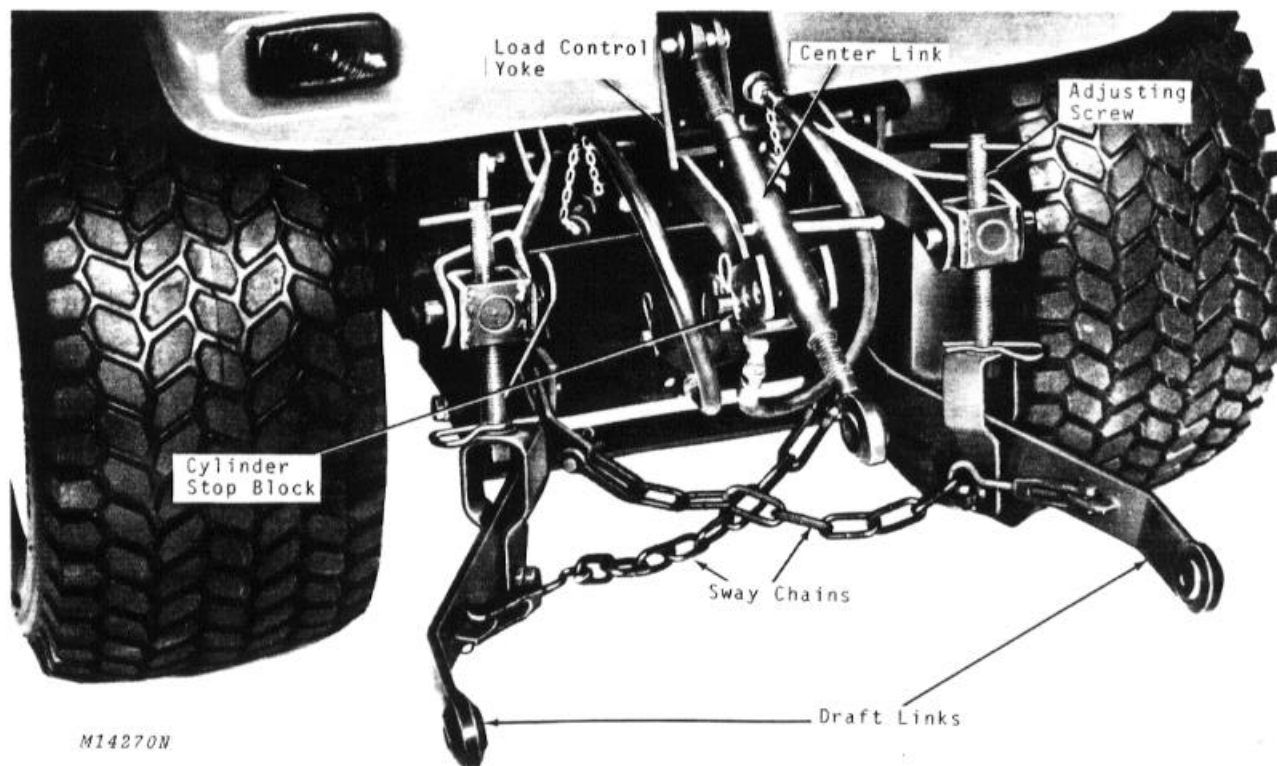

M14270N

CONTROL FUNCTION OPTIONS

1. Rear hydraulic system controlled by OUTER LEVER.

A. Outer lever operates the rear hydraulic system (cylinder lock-out link required). The left front couplers and rockshaft cylinder.

B. Inner lever permits float and operates the right front couplers.

2. Rear hydraulic system controlled by INNER LEVER.

A. Inner lever operates the rear hydraulic system, the right front couplers, and permits float to both.

B. Outer lever operates the rockshaft cylinder and left front couplers.

INSTALLING REAR HYDRAULIC SYSTEM ON 300 TRACTOR (Rear Hydraulic System Controlled by ~~Inner~~ Control Lever)

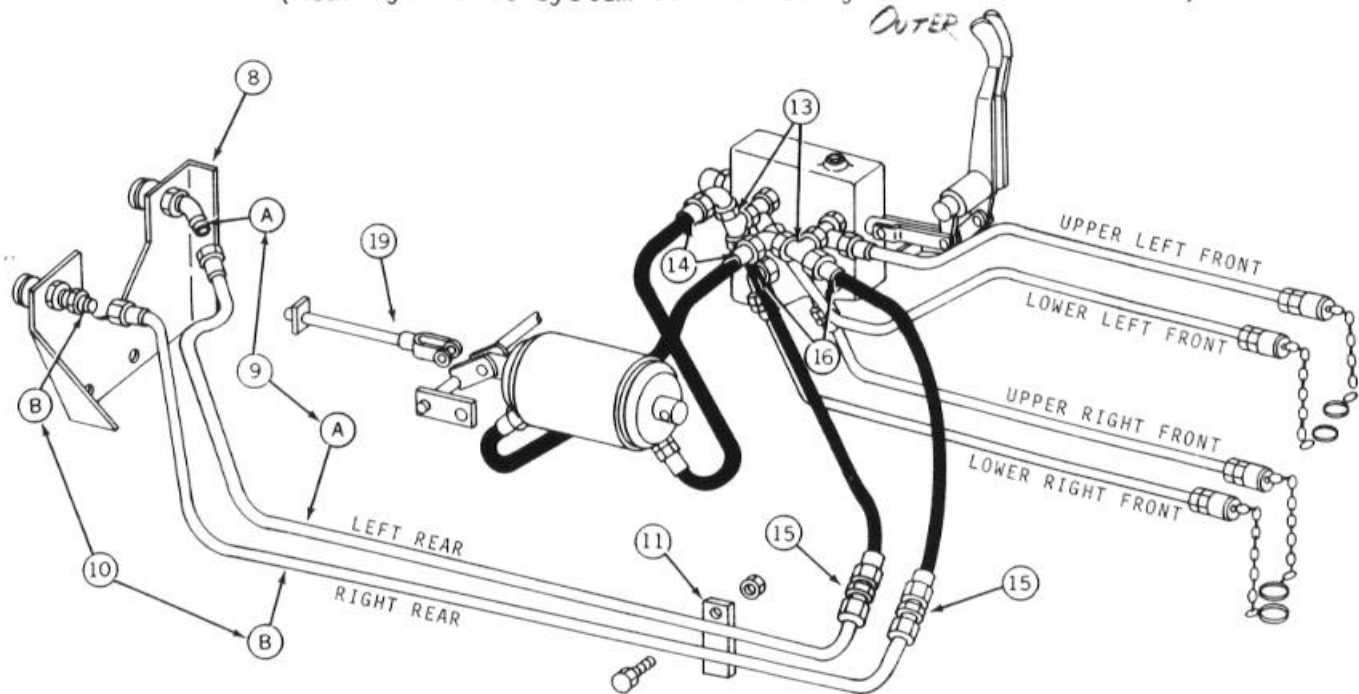

NOTE: Right-hand (RH) and left-hand (LH) references are determined by standing at the rear of the tractor and facing direction of forward travel.

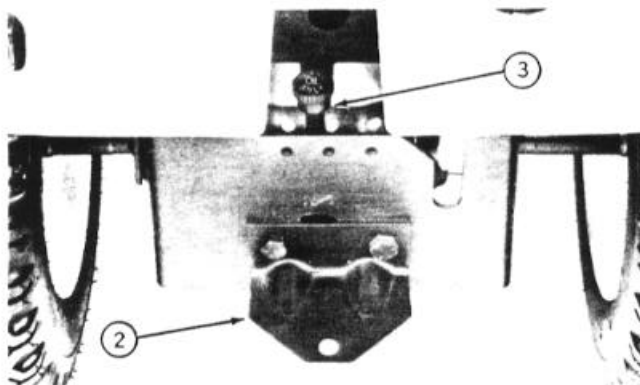

1. Remove fender deck. Close fuel shut-off valve and remove fuel tank. (Not illustrated.)

2. Remove hitch.

3. Place a drain pan under transmission and remove the oil fill tube at the rear axle.

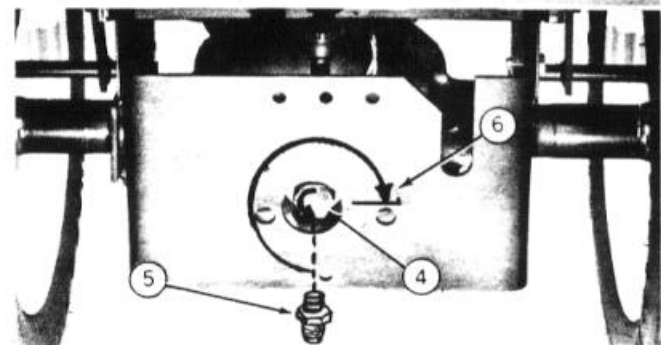

4. Place connector washer between fitting and transaxle. Rotate fitting counterclockwise until hole in fitting points downward.

5. Insert connector into fitting.

6. Rotate fitting clockwise until connector points toward right side of tractor.

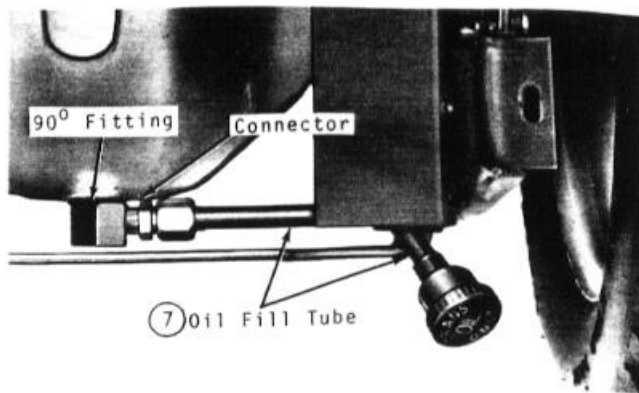

Top View of Oil Fill Tube When Installed Correctly

7. Install new (angled) oil fill tube onto connector.

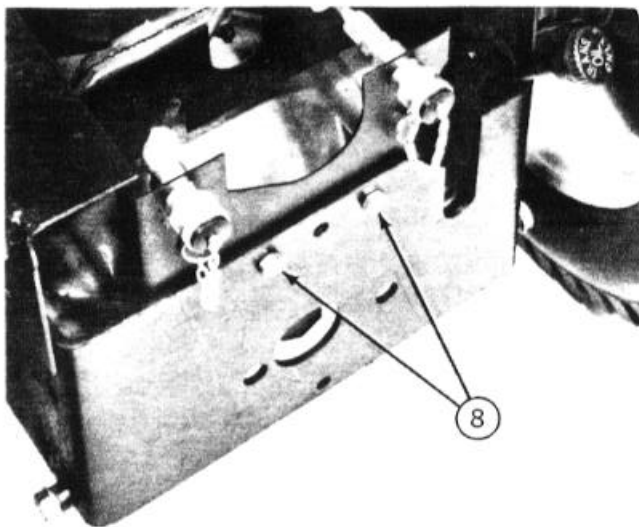

8. Attach coupler mounting plate to frame with two 3/8" x 1" cap screws, one flat washer (use flat washer at slotted hole) and nuts.

9. Attach hydraulic tube (A) (left rear) to connector (A).

10. Attach hydraulic tube (B) (right rear) to connector (B).

11. Remove and discard 3/8" x 1" cap screw from front of right-hand lift shaft bearing. Install tube clamp with 3/8" x 1-1/4" cap screw.

12. Disconnect cylinder oil hoses from tee fittings on control valve. (Not illustrated.)

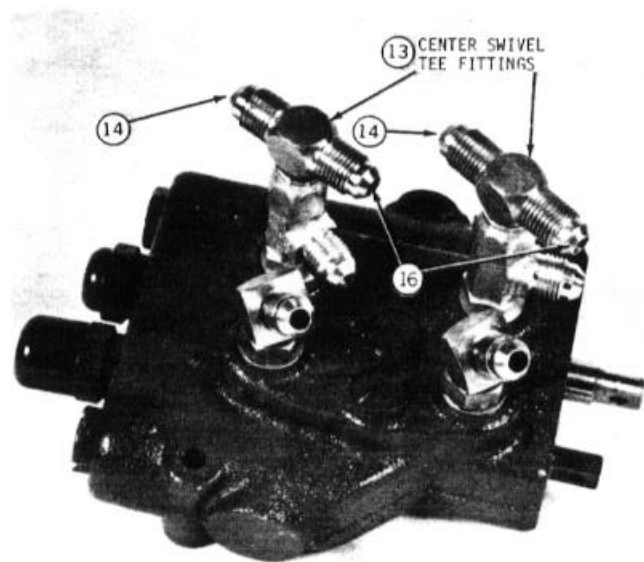

13. Install center swivel tee fittings onto tee fittings presently in control valve. Angle fittings slightly rearward.

14. Install oil hose from front (piston end) of cylinder to rear of rear tee swivel. Install oil hose from rear of cylinder to rear of front tee swivel.

15. Attach 1/2" straight fittings to hydraulic hoses. Attach hydraulic hoses to rear hydraulic tubes.

16. Attach hydraulic hoses from front end of tee swivels to rear hydraulic tubes as illustrated.

17. Check oil level in transmission with engine running and hydrostatic control lever in neutral. Be sure oil level is at the top of black "SAFE" range.

18. Start engine. Bleed air from oil lines by moving the control lever back and forth while unseating ball in each rear coupler.

19. When rear hydraulic lines are connected as shown, the cylinder lockout link is required to prevent delay in hydraulic function. See page 8.

NOTE: When the rear hydraulic kit is installed as shown, the rear hydraulic function will be controlled by the outer hydraulic lever.

INSTALLING REAR HYDRAULIC SYSTEM ON 300 TRACTOR
(Rear Hydraulic System Controlled by Inner Control Lever)

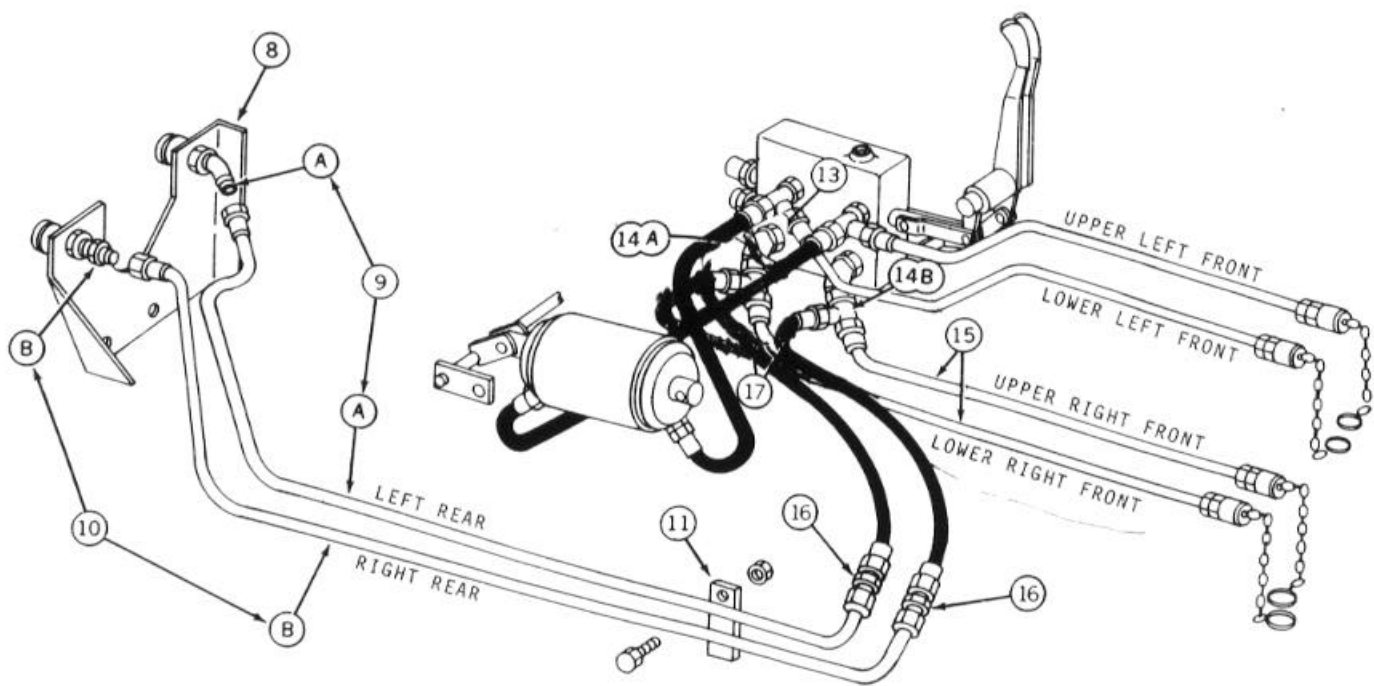

NOTE: Right-hand (RH) and left-hand (LH) references are determined by standing at the rear of the tractor and facing direction of forward travel.

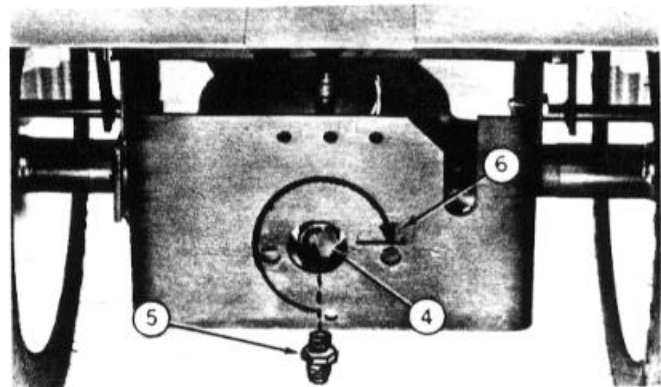
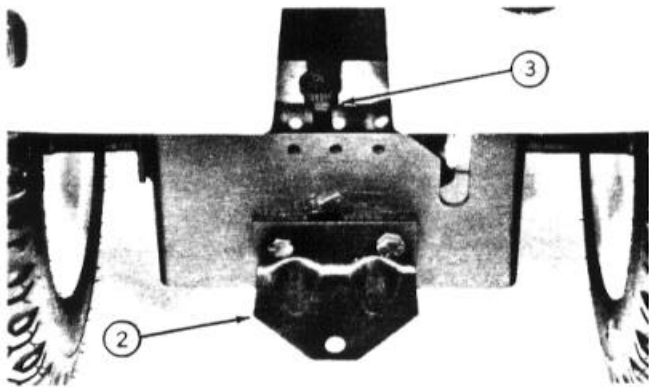

1. Remove fender deck. Close fuel shut-off valve and remove fuel tank. (Not illustrated.)

2. Remove hitch.

3. Place a drain pan under transmission and remove the oil fill tube at the rear axle.

4. Place connector washer between fitting and transaxle. Rotate fitting counterclockwise until hole in fitting points downward.

5. Insert connector into fitting.

6. Rotate fitting clockwise until connector points toward right side of tractor.

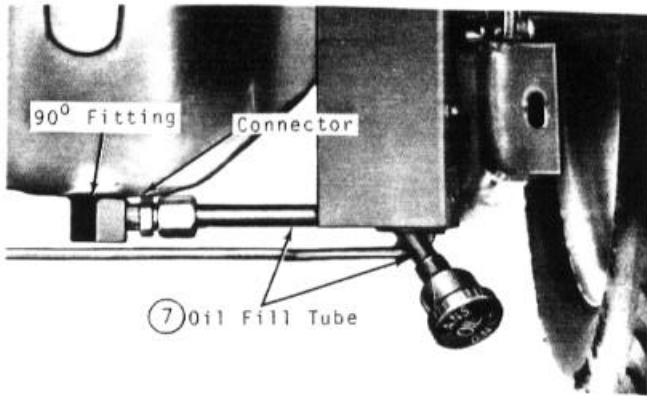

Top View of Oil Fill Tube When Installed Correctly

7. Install new (angled) oil fill tube onto connector.

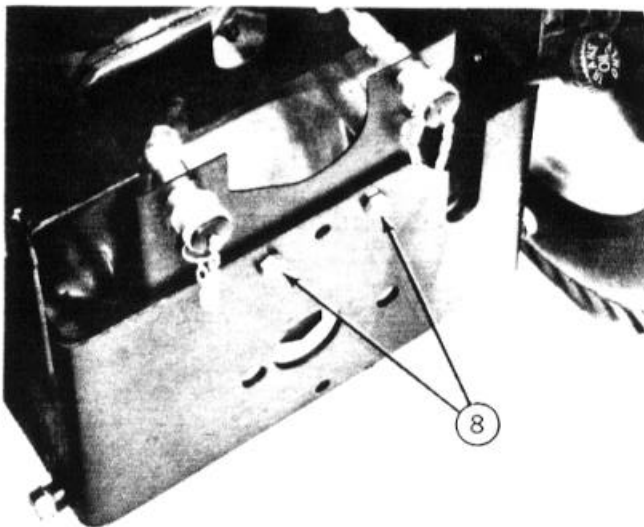

8. Attach coupler mounting plate to frame with two 3/8" x 1" cap screws, one flat washer (use flat washer at slotted hole) and nuts.

9. Attach hydraulic tube (A) (left rear) to connector (A).

10. Attach hydraulic tube (B) (right rear) to connector (B).

11. Remove and discard 3/8" x 1" cap screw from front of right-hand lift shaft bearing. Install tube clamp with 3/8" x 1-1/4" cap screw.

12. Remove and discard the two right front hydraulic tubes. (Not illustrated.)

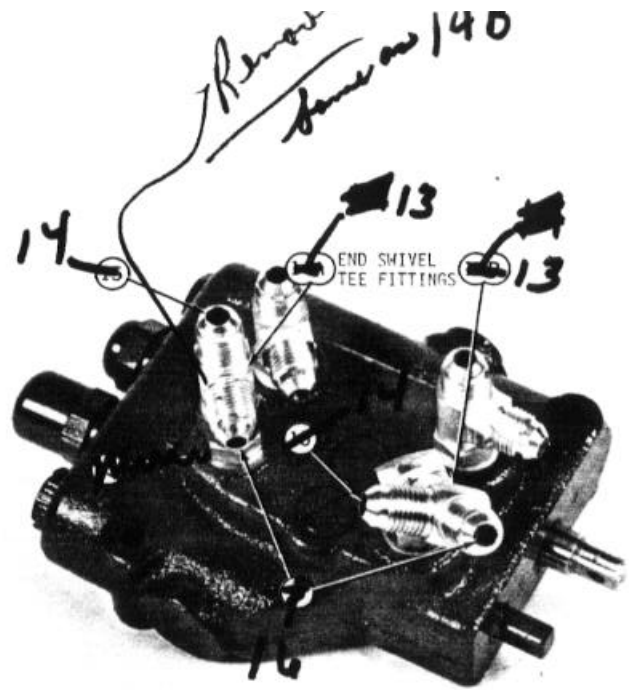

13. Remove and discard the rear 45° adjustable elbow (not illustrated). Install a straight fitting as shown.

13 14. Attach ~~one end swivel tee to the straight fitting~~ and ~~one end swivel tees to 45° fittings~~.

14 15. Install new front hydraulic tubes to couplers and swivel tees as illustrated.

15 16. Attach 1/2" straight fittings to hydraulic hoses. Attach hydraulic hoses to rear hydraulic tubes.

16 17. Attach hydraulic tubes from end swivel tees to rear hydraulic tubes as illustrated.

17 18. Check oil level in transmission with engine running and hydrostatic control lever in neutral. Be sure oil level is at the top of black "SAFE" range.

18 19. Start engine. Bleed air from oil lines by moving the control lever back and forth while unseating ball in each rear coupler.

NOTE: When the rear hydraulic kit is installed as shown, the rear hydraulic function will be controlled by the inner hydraulic lever.

INSTALLING 3-POINT HITCH ON 300 OR 140 TRACTORS

ATTACHING MOUNTING FERRULES

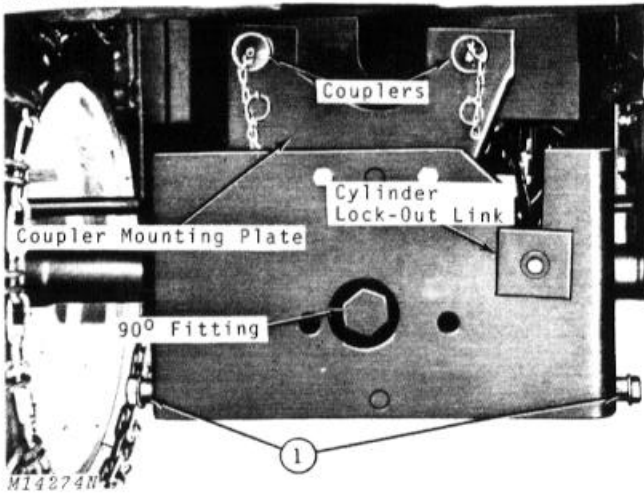

1. Install mounting ferrules in bottom hole on each side of tractor hitch plate with 1/2 x 1-1/2-inch bolts. Use flat washer between bolt head and ferrule. Use lock washer between nut and inside of tractor hitch plate.

ATTACHING HITCH ON TRACTOR

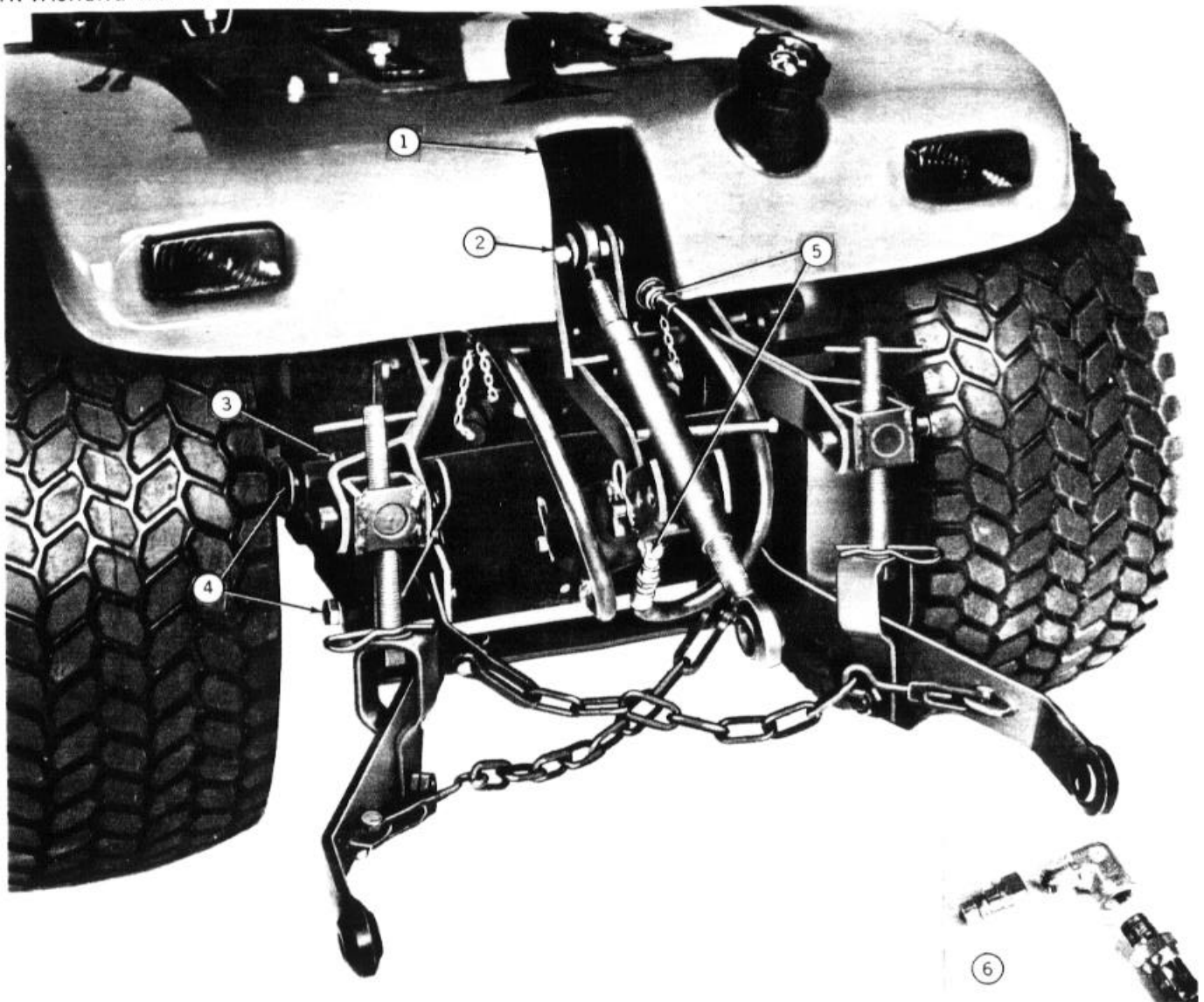

1. Remove cover from fender deck. Store cover for future use.

NOTE: Remove PTO drive shaft extension, if tractor is so equipped. See 33 Rotary Tiller operator's manual for removal instructions.

2. Assemble center link to top hole of lift yoke with 5/8 x 2-3/4-inch drilled pin. Install drilled pin through center link from left to right. Secure with large spring locking pin.

3. Place spring-loaded pins in extracted position.

4. Position hitch bracket on mounting ferrules and lift hitch against tractor hitch plate until spring loaded pins can be released.

5. On a 300 Tractor (illustrated), attach hose from piston end of cylinder to right hydraulic coupler. Install hose from opposite end of cylinder to left hydraulic coupler.

6. For 140 Tractors, assemble fittings as shown, see inset. Attach hose from piston end of cylinder to bottom coupler and hose from opposite end of cylinder to top coupler (not illustrated).

INSTALLING 3-POINT HITCH ON 300 OR 140 TRACTORS - Continued

CYLINDER LOCK-OUT LINK

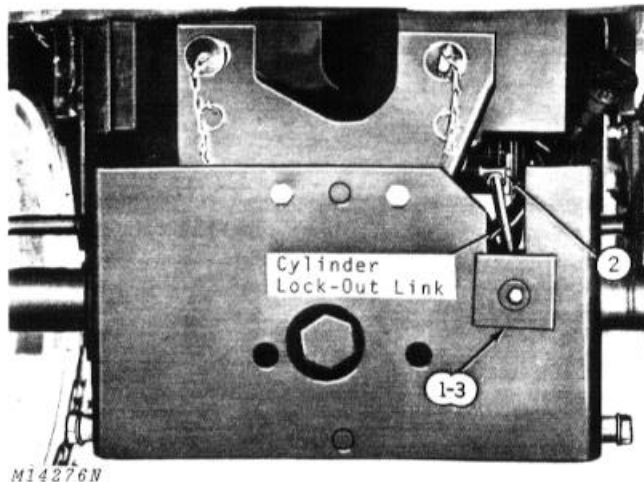

M14276N

A lockout link is provided to prevent the rockshaft cylinder from operating. This allows for instant operation of remote cylinders and equipment.

On the 300 Tractor, use the cylinder lockout link when the rear hydraulics are installed as shown on page 2.

NOTE: This lockout link is also required for 140 H-3 Tractors. If the optional method of assembling the rear hydraulic system is used as illustrated in instructions of AM36001 Conversion Kit.

To install lockout link, adjust depth stop to lowest position and lower rockshaft arms.

1. Install link in hitch plate slot with retainer outside tractor hitch plate.
2. Fasten forward end to rockshaft lift arm with $\frac{3}{8}$ x $1\frac{1}{4}$ -inch drilled pin and spring locking pin.
3. Loosen clevis lock nut and rotate lock-out link until firmly seated against rear hitch plate. Tighten lock nut.

LUBRICATION

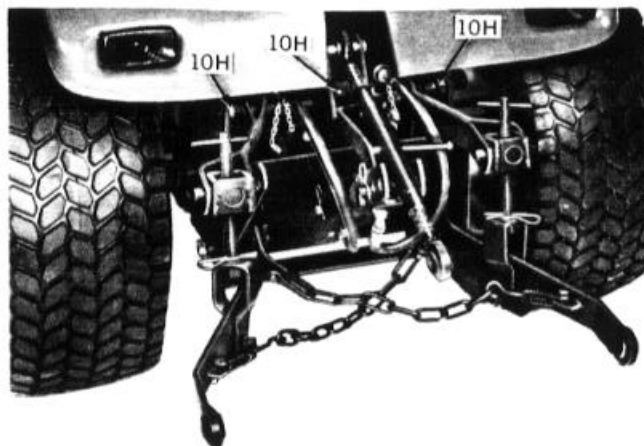

M14277N

Bearings should be lubricated every 10 hours of operation.

OPERATION AND ADJUSTMENTS OF 3-POINT HITCH

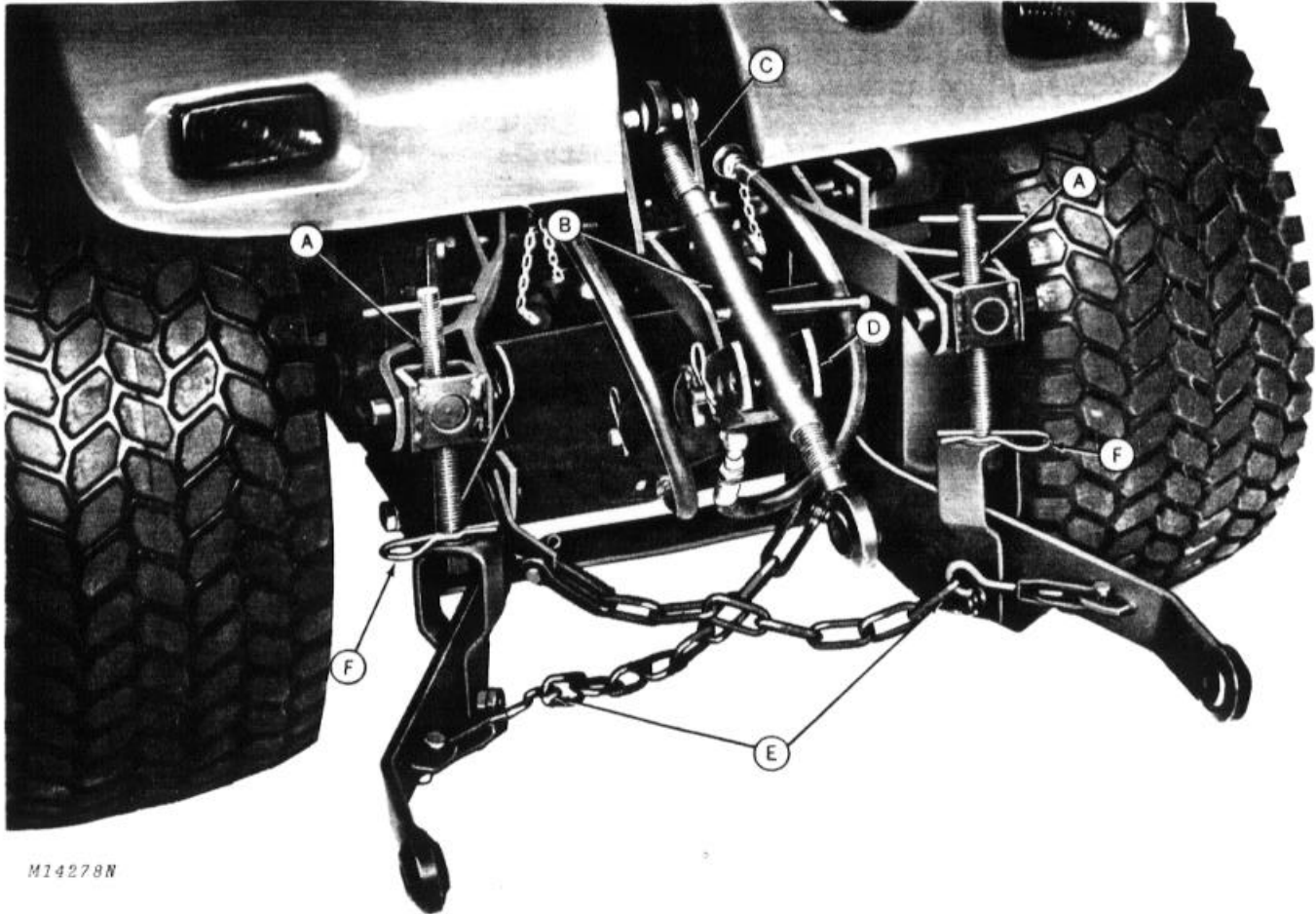

M14278N

NOTE: Two BM15708 Front Wheel Weights available as extra equipment, are recommended when operating rear mounted equipment.

1. Depth and Leveling Adjustments

A. Adjusting screws are used to level the implement and provide an alternate method of depth control.

B. The center link is used for front to rear leveling of implements.

2. Lift Adjustments

C. The load control yoke has three adjustments. Use the top hole for plowing and tilling. Use the center or lower hole for cultivating and low draft applications.

D. The cylinder stop is adjustable to increase or decrease lift in 1-inch increments.

3. Sway Adjustments

E. Sway chains limit the side sway of the hitch.

4. Float Operation

F. Float operation of hitch is accomplished by removing spring locking pins at the bottom of adjusting screws.

REMOVAL OF 3-POINT HITCH

1. Disconnect cylinder hoses from hydraulic couplers. Place dust caps over hose ends and dust plugs into couplers.
2. Pull spring-loaded pins to extracted position. Allow hitch bracket to pivot downward and lift hitch off mounting ferrules.

3. Replace PTO cover in fender deck opening.
4. Release spring-loaded pins after hitch is removed.

NOTE: Remove lockout link to use rockshaft cylinder.

